

CALIFORNIA TOWNSHIP

T 32 N, R 2 W

G15

SECTION 10

SECTION 10

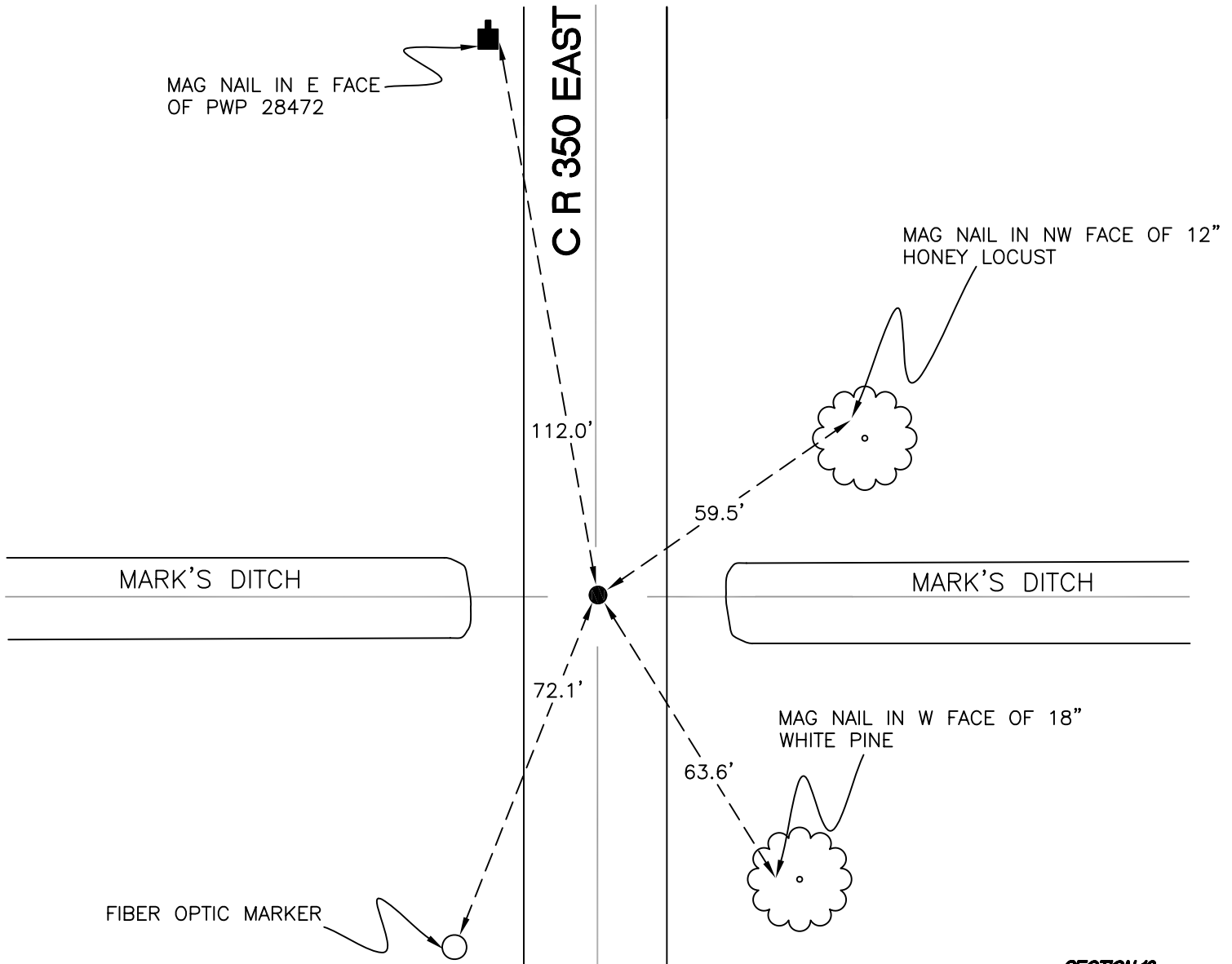

SECTION 10

SECTION 10

MONUMENT: 5/8" IRON ROD

PARTY: JL/AO

DATE: 7/11/12

COMMENTS: 2" BELOW GRADE. COMMON REPORT BY TERRITORIAL ENGINEERING DOCUMENT #'s 2007004957 AND 2010003222.

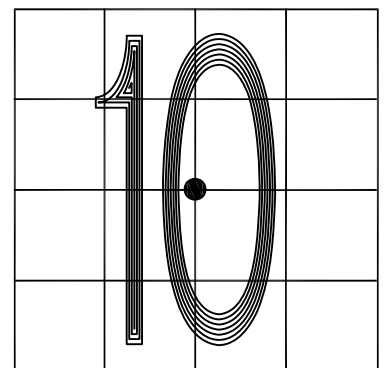

CORNER LOCATION IN THE SECTION

G15